

HAND CARRY AXLE JACK

Product Data Sheet



Model CJ67D0250-1 – 15 Ton Capacity

NSN: 1730-00-854-2237
CAGE CODE: 69134

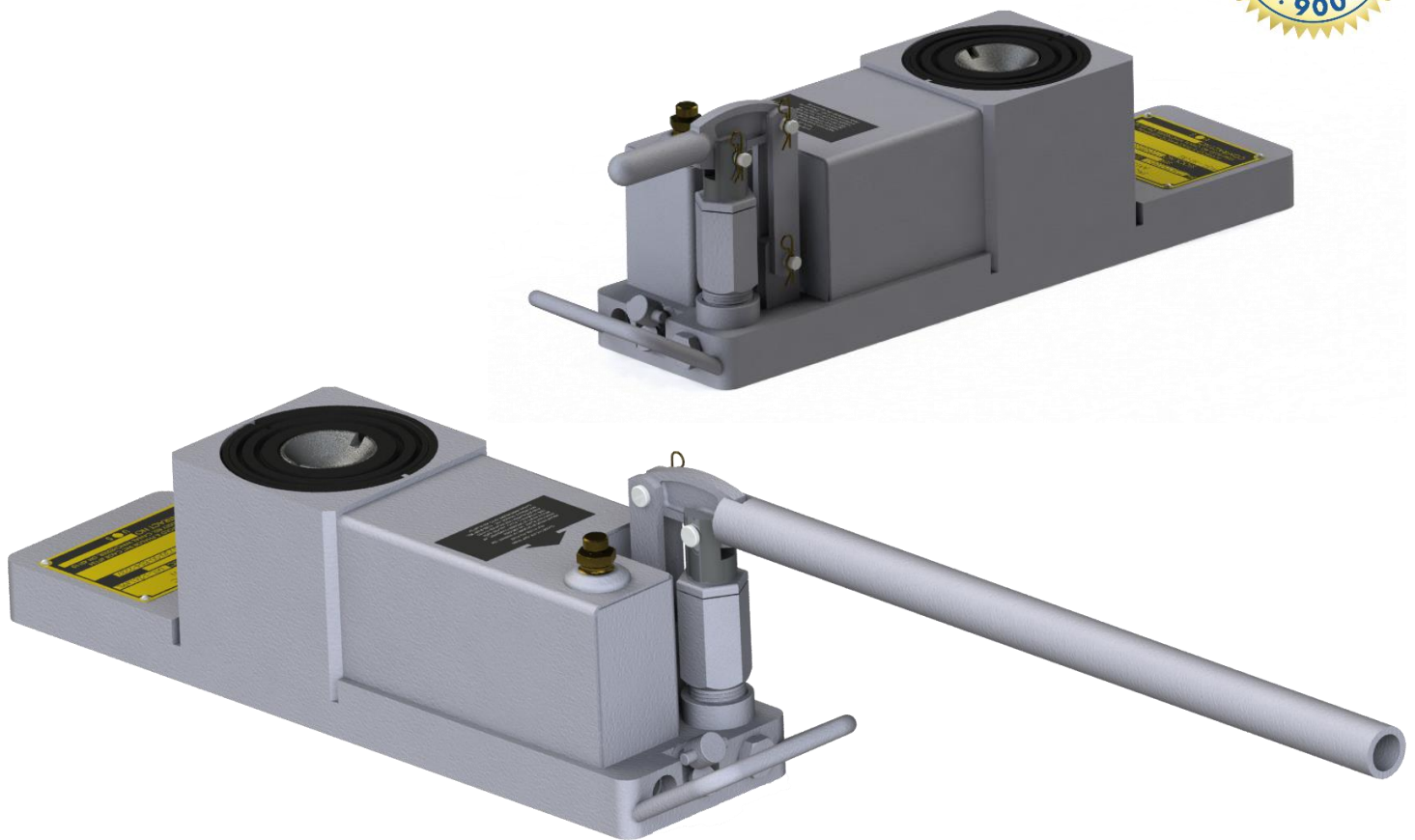

SPECIFICATIONS

	<u>Standard</u>	<u>Metric</u>
Vertical Capacity	30,000 lbs	13,608 kg
Hydraulic Lift	7.63 in	194 mm
Screw Extension	2.56 in	65 mm
Minimum Height (closed)	4.75 in	121 mm
Maximum Extended Height	14.94 in	380 mm
Jack Net Weight (estimate)	50 lbs	23 kg
Jack Overall Dimensions (length x width x height)	21 in x 9 in x 11 in	533 mm x 229 mm x 279 mm
Crate Weight (estimate)	68 lbs	30.8 kg
Crate Dimensions (estimate) (length x width x height)	23 in x 11 in x 17 in	584 mm x 279 mm x 432 mm

CONTACT

Manifold & Phalor, Inc.
10385 Busey Road
Canal Winchester, Ohio 43110

Phone: 614.920.1200
Fax: 614.920.1205
sales@manifoldphalor.com



**Manifold
& Phalor**

www.manifoldphalor.com